

# CRACK PITTS XL

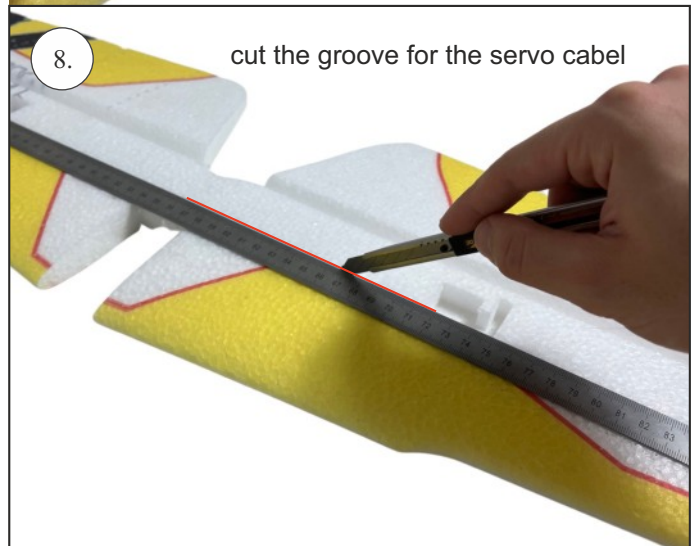

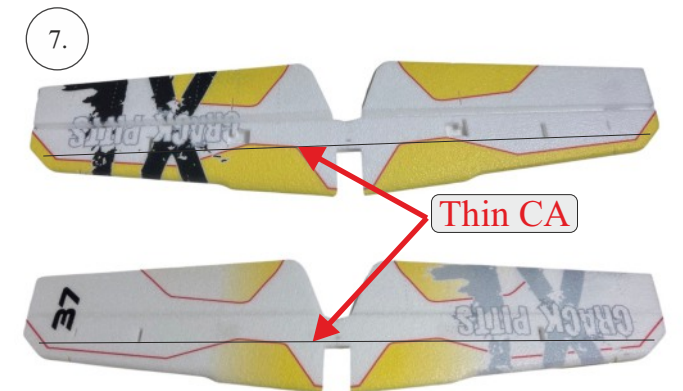

Do the same on the both wings

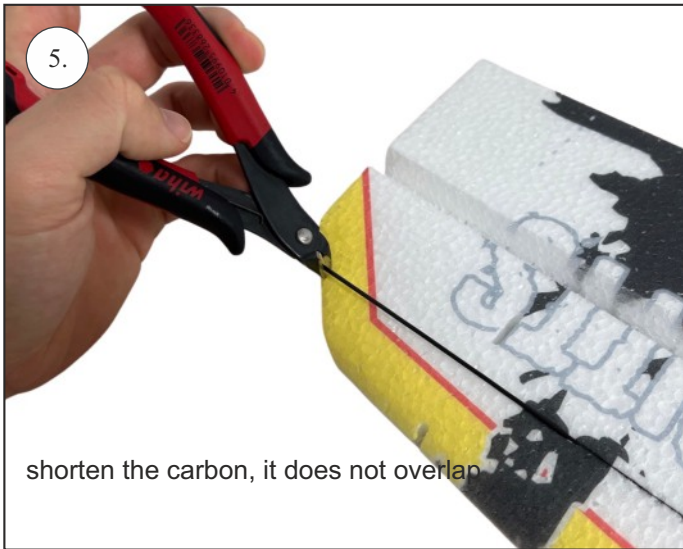
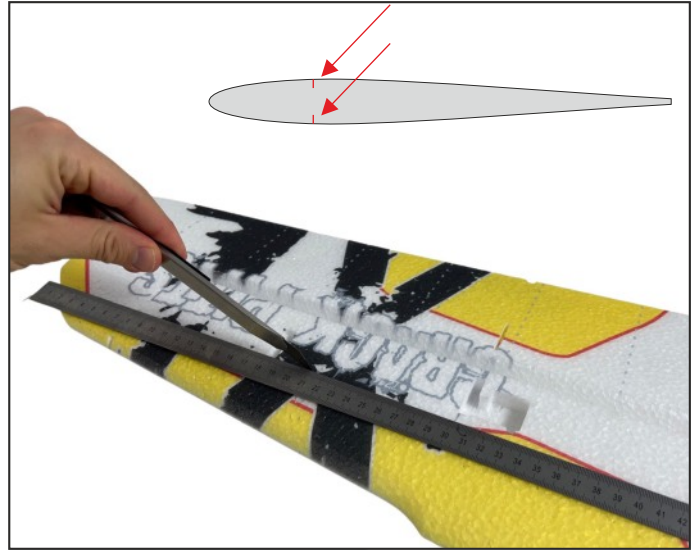
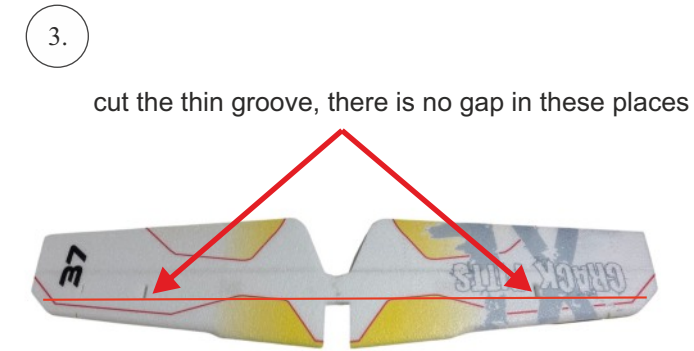
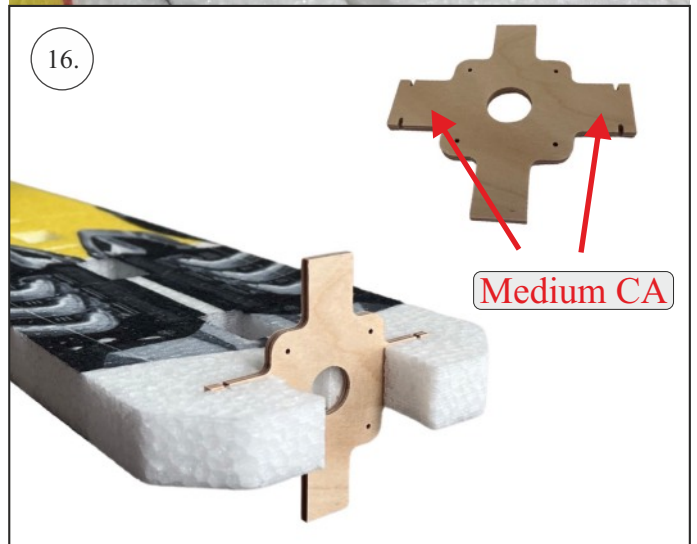
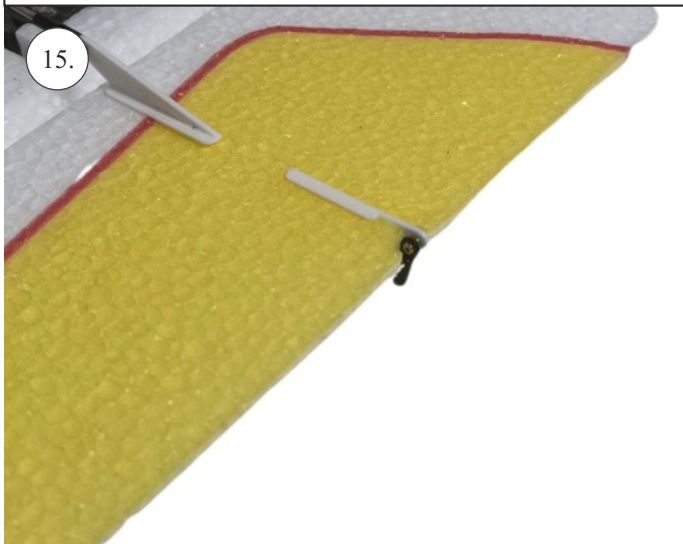
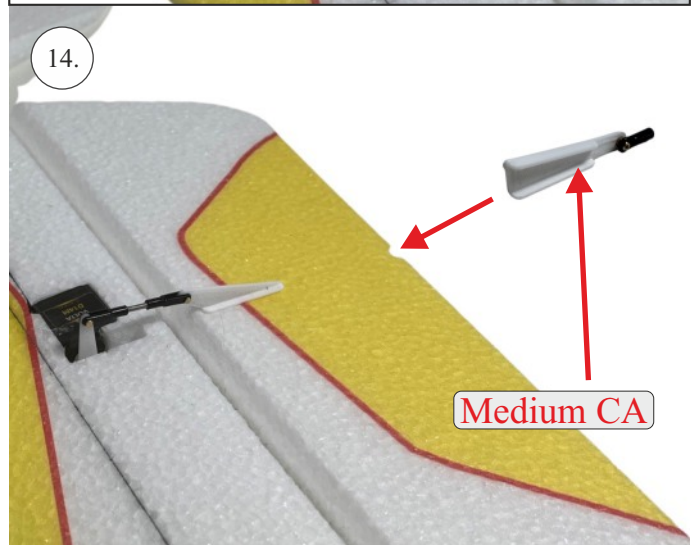
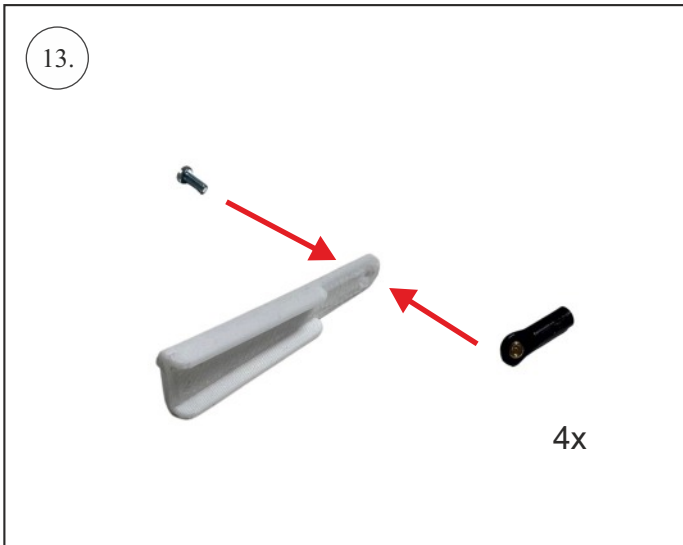
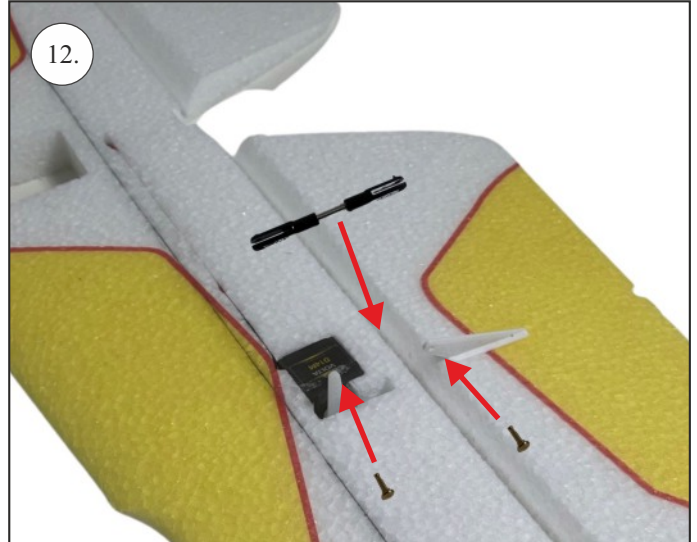
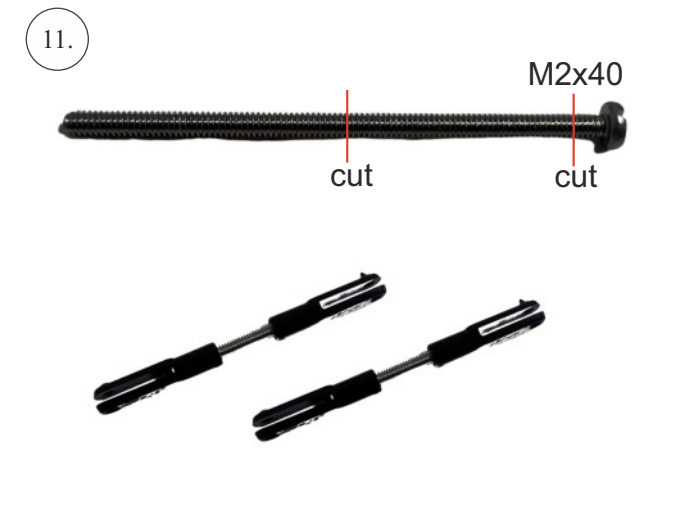

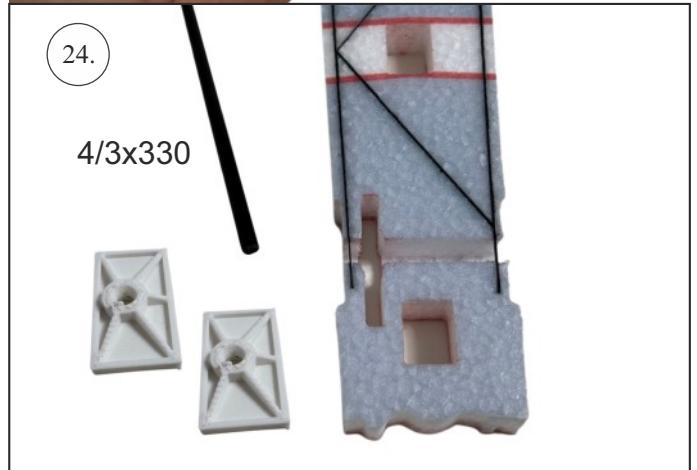
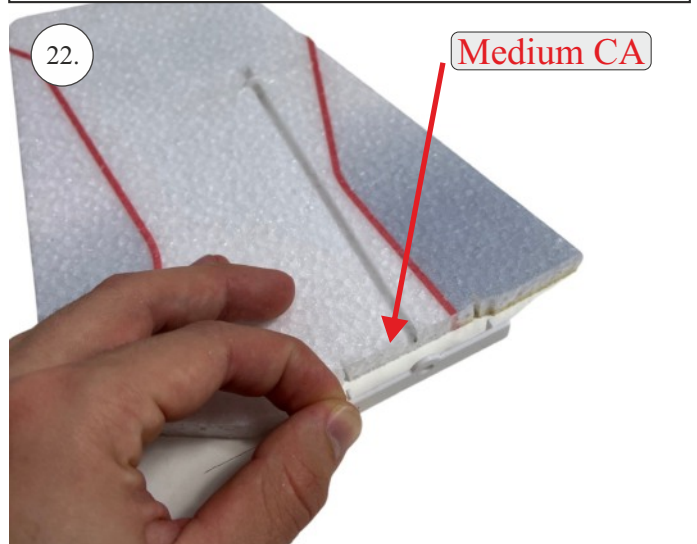
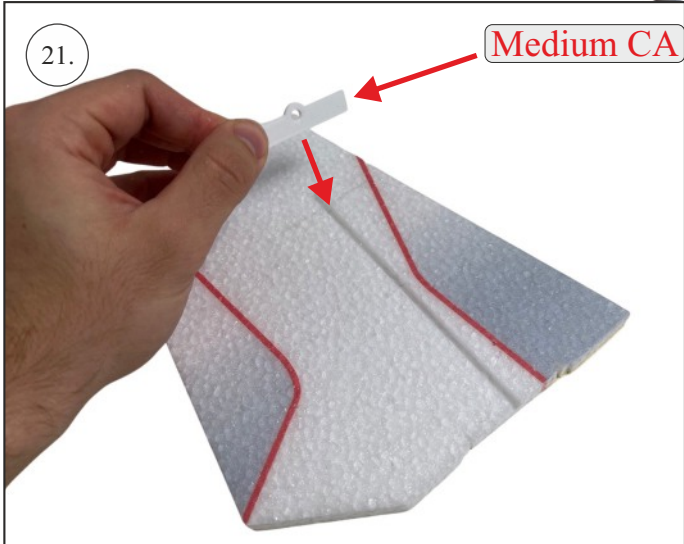
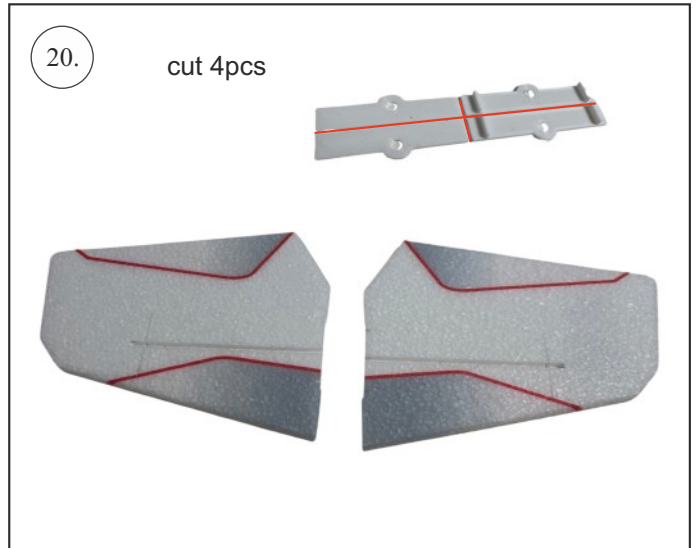
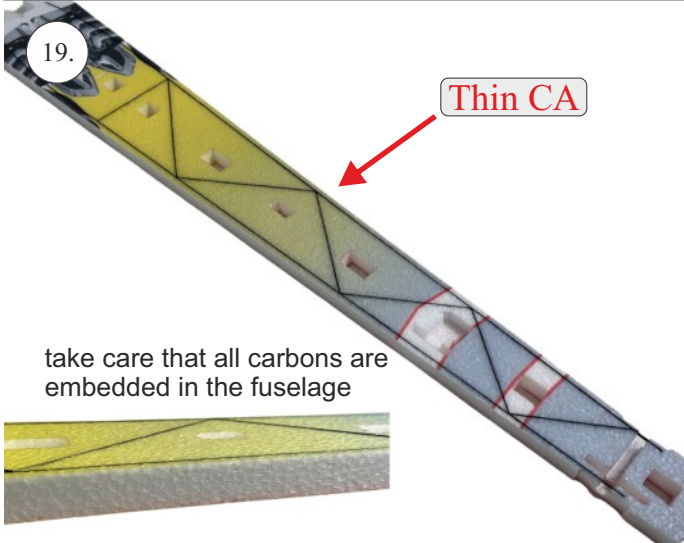
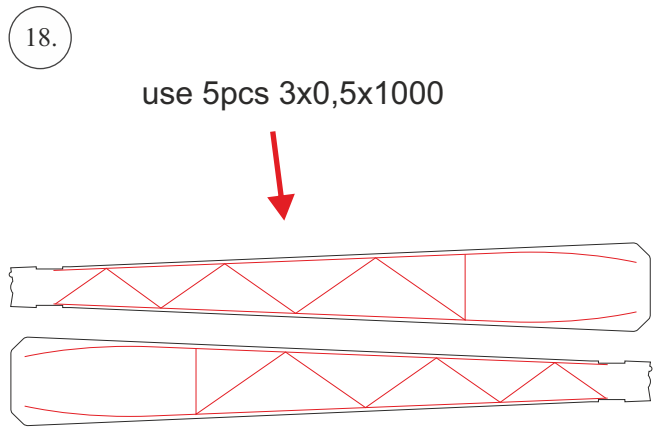
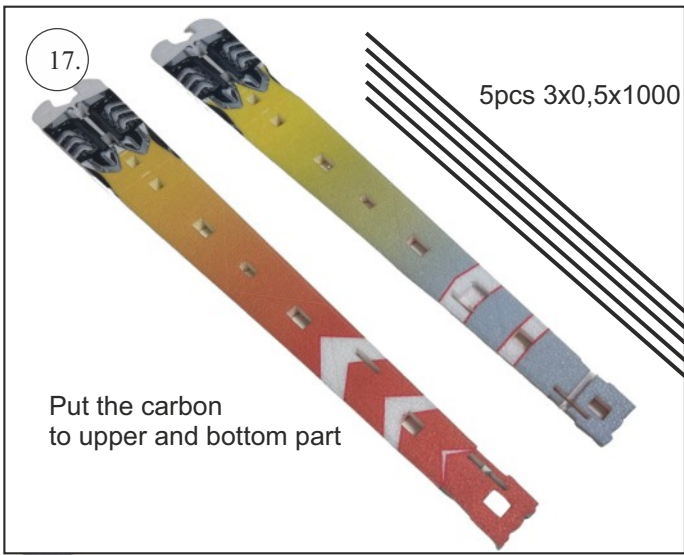

elevators are prepared for the next steps

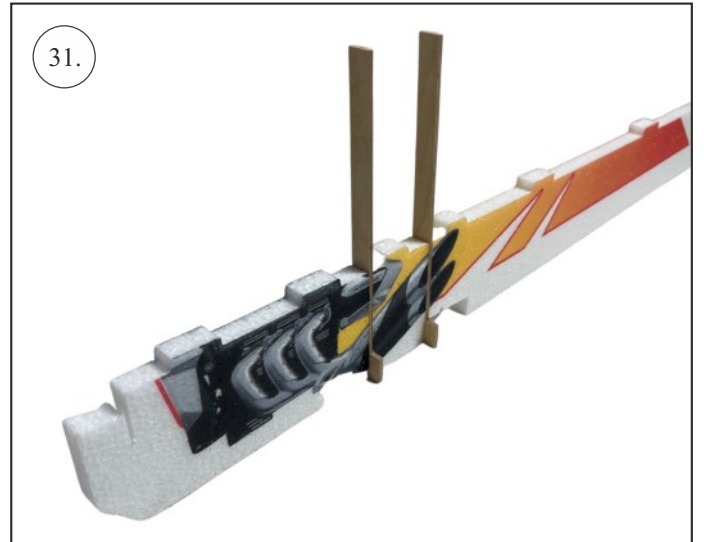
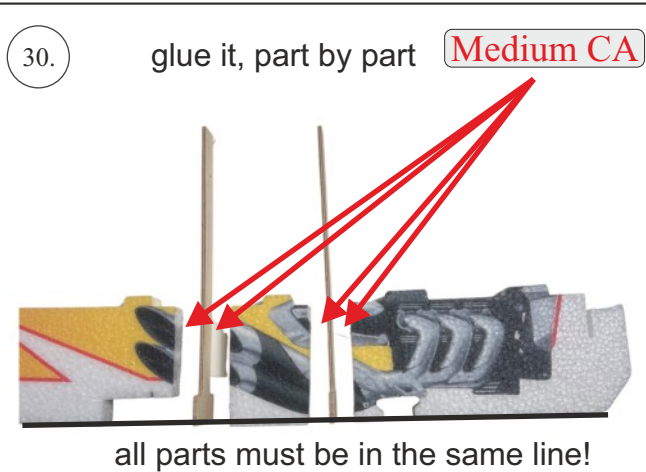
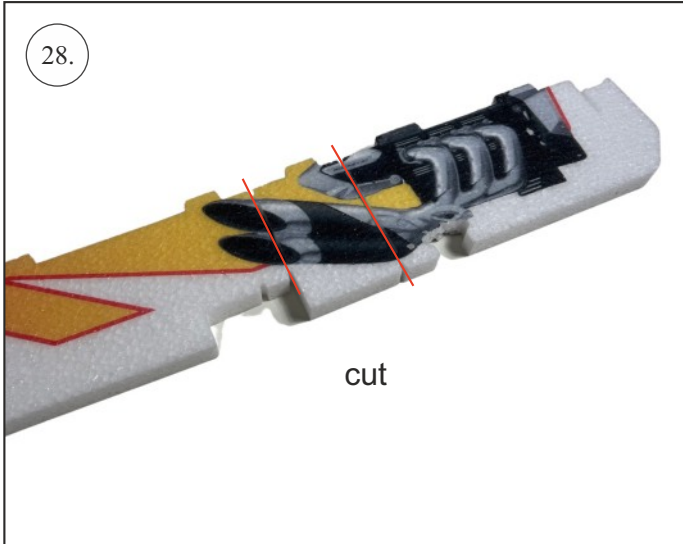
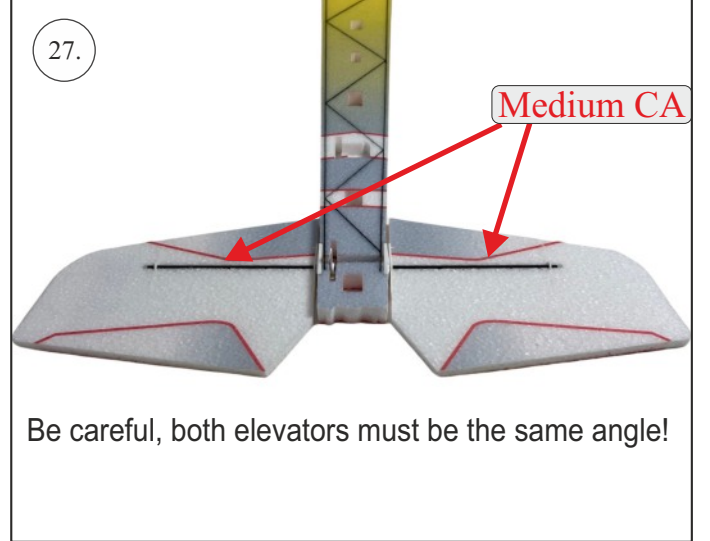
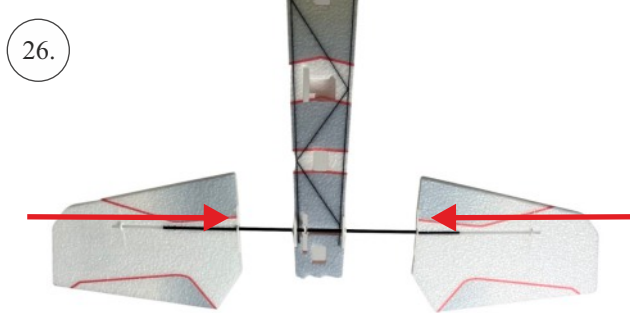
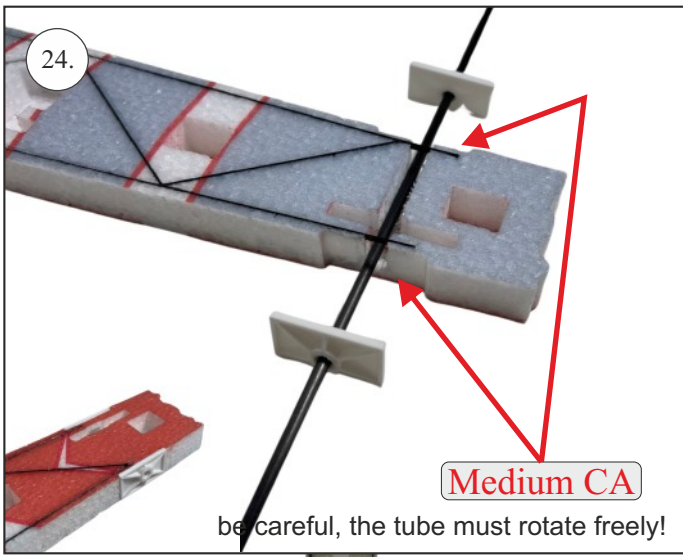

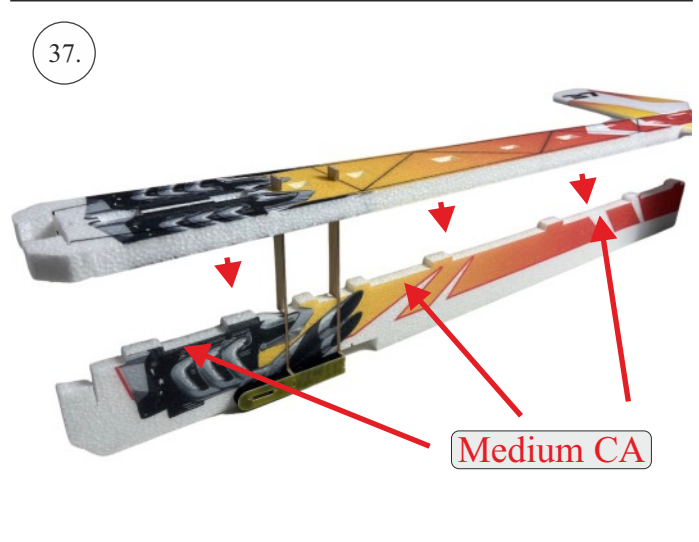
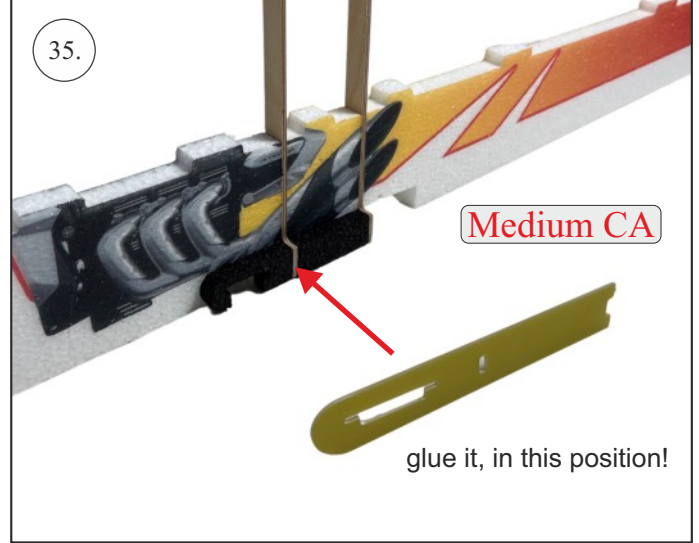
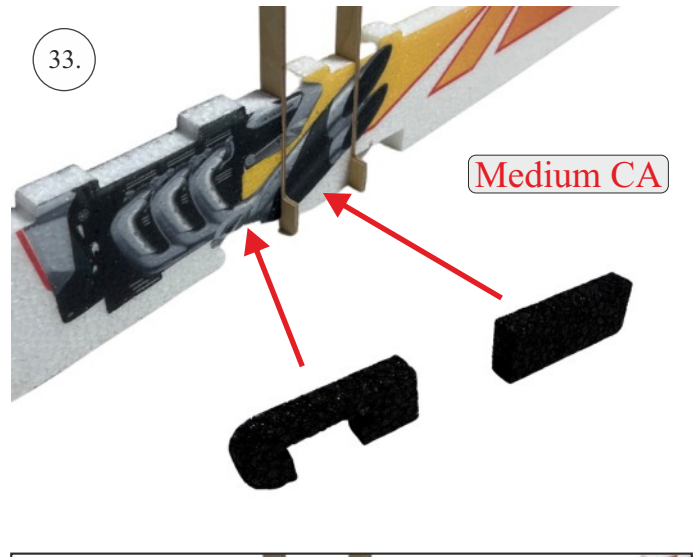
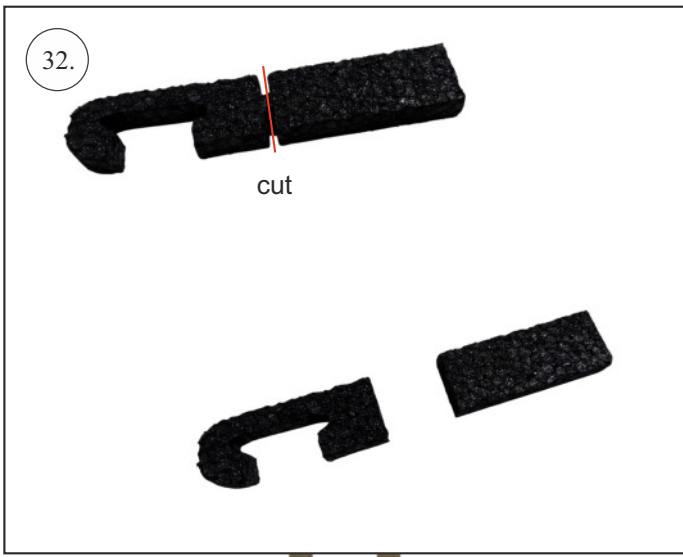

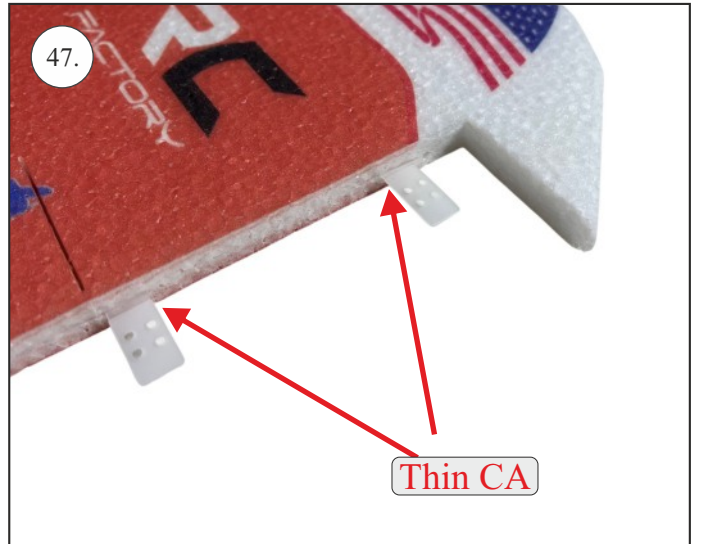
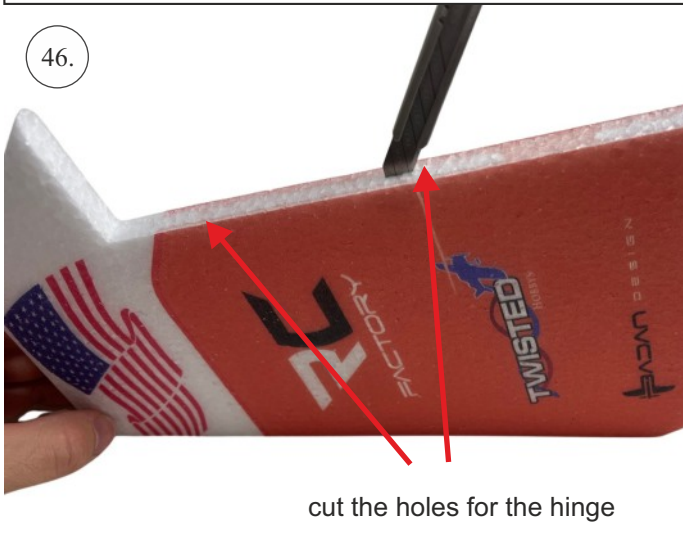
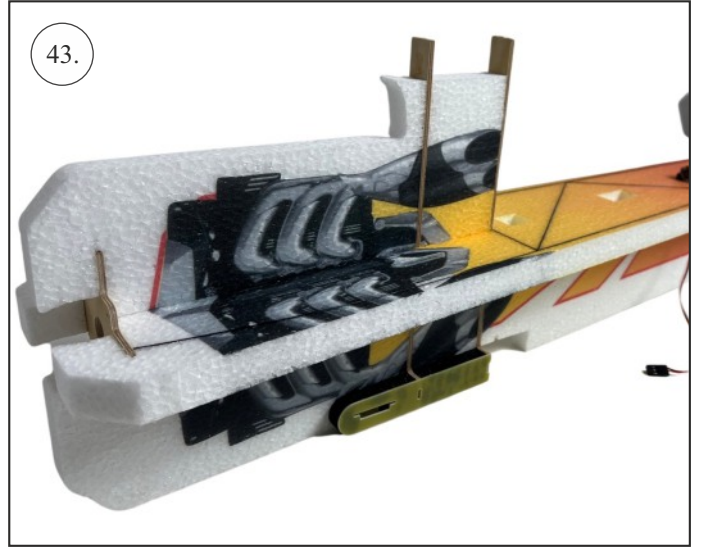
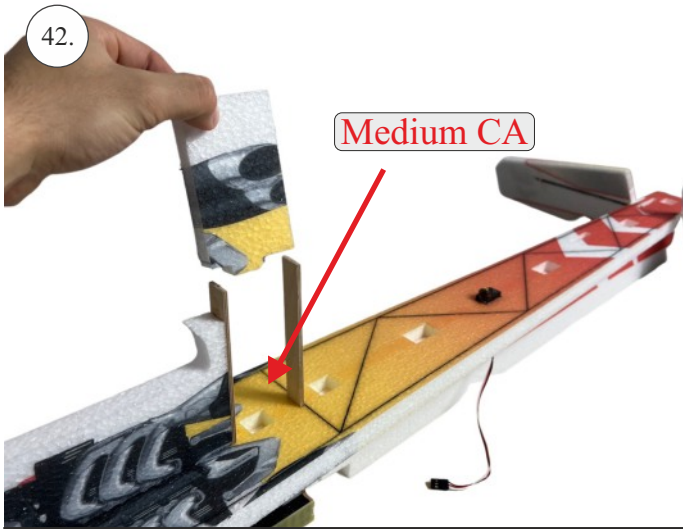
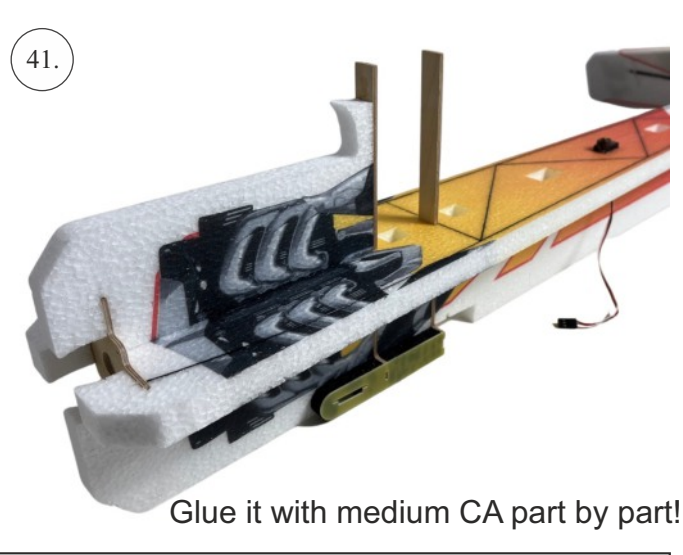
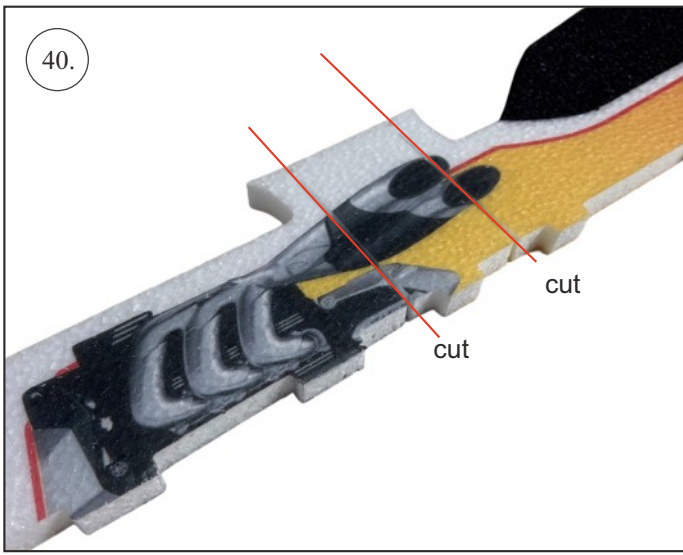

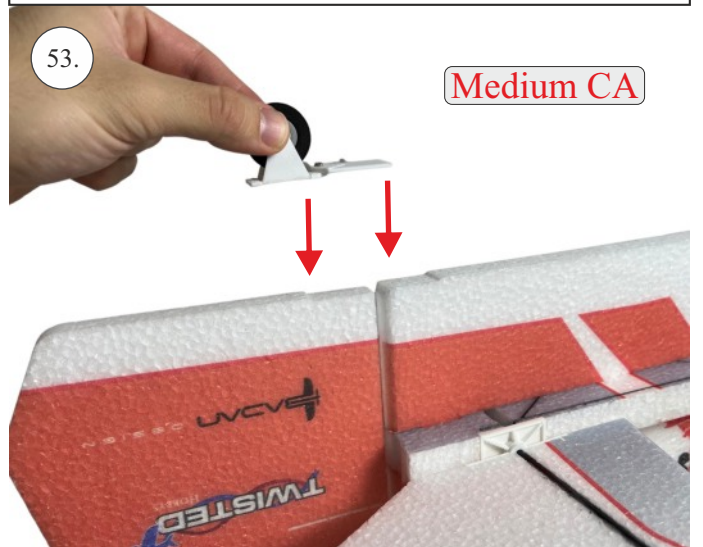
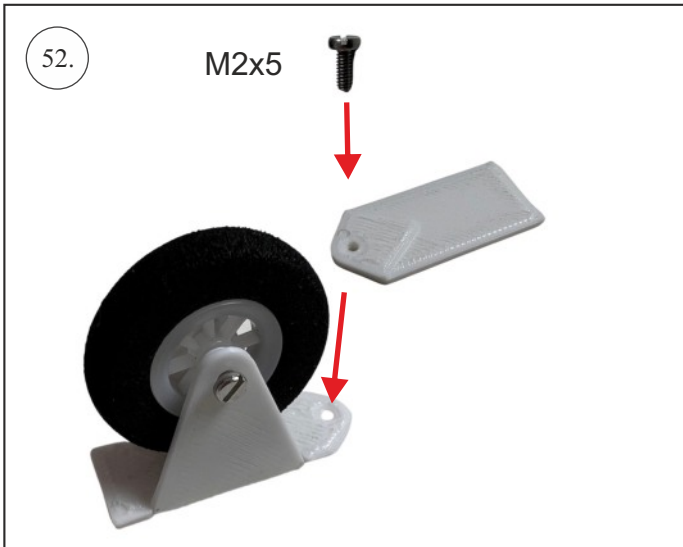
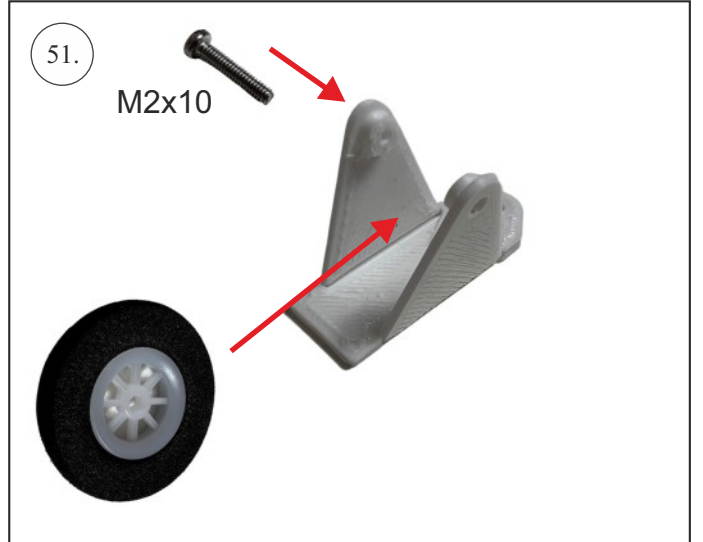
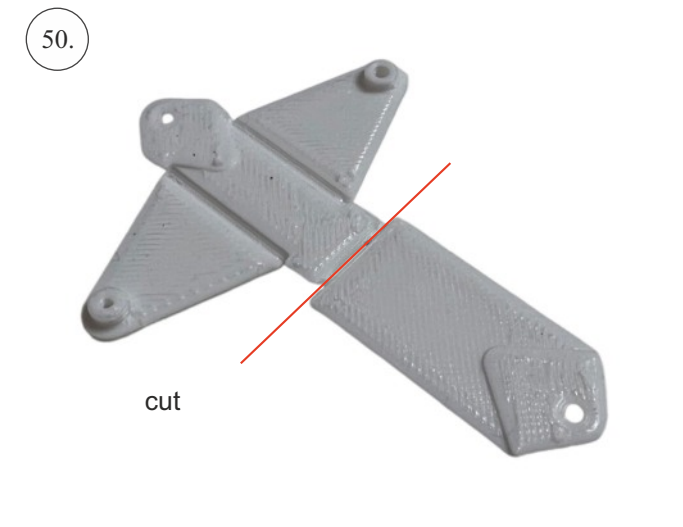
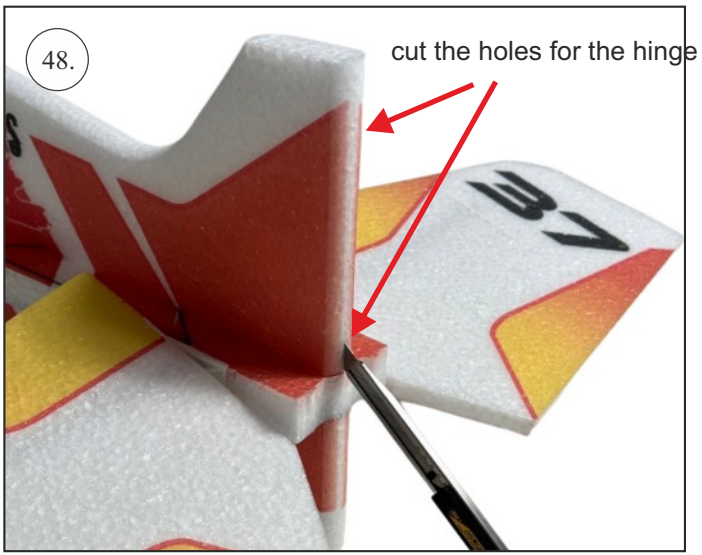



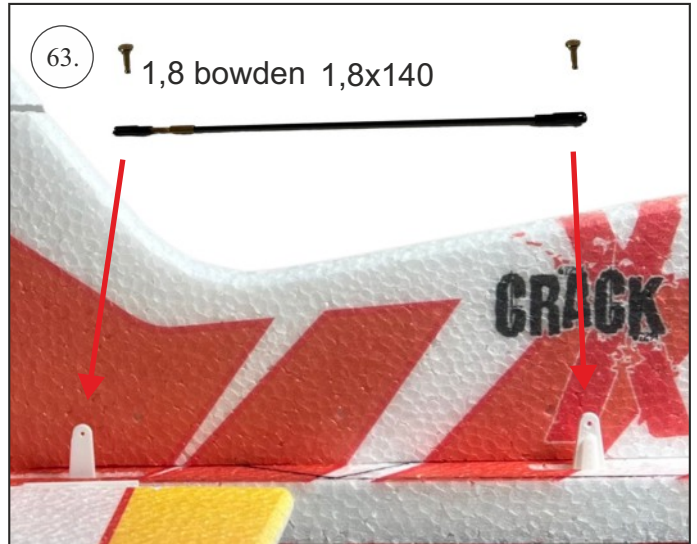
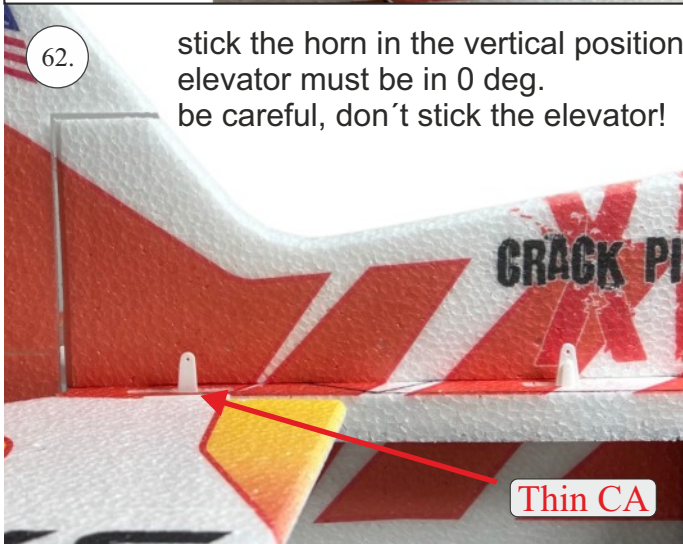
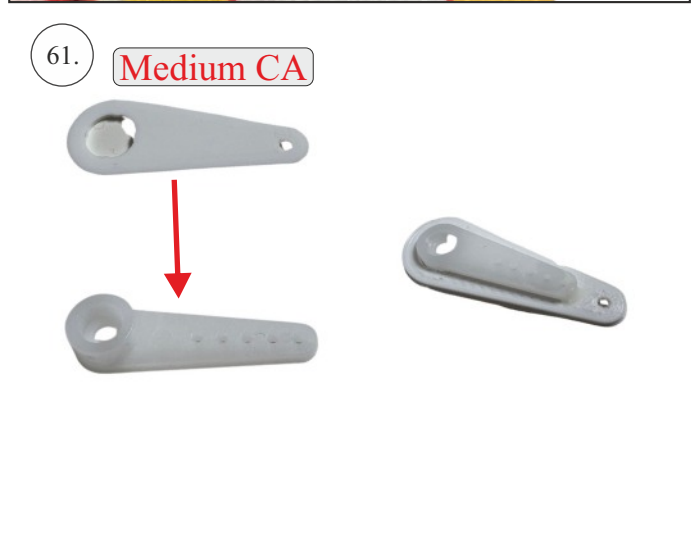
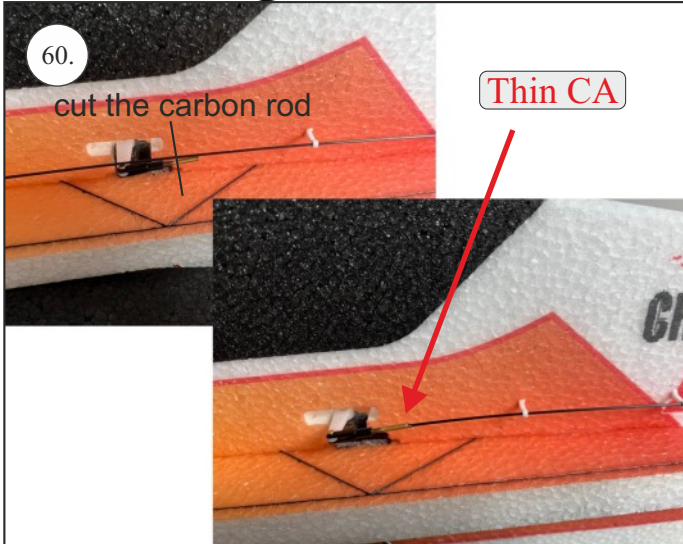
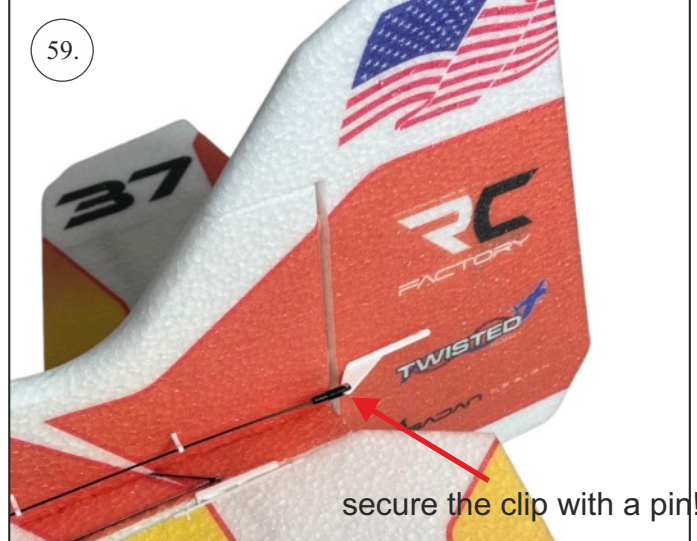
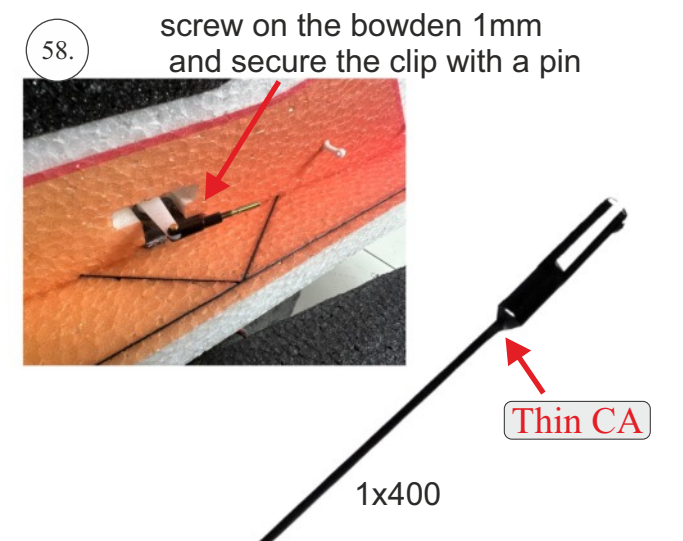
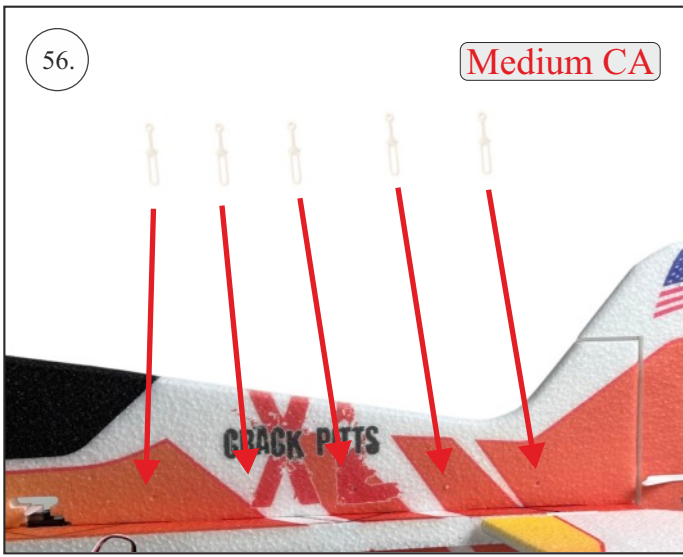

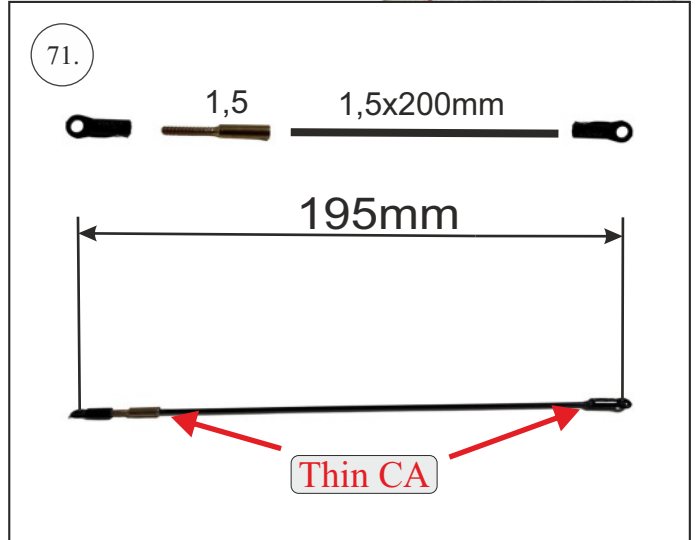
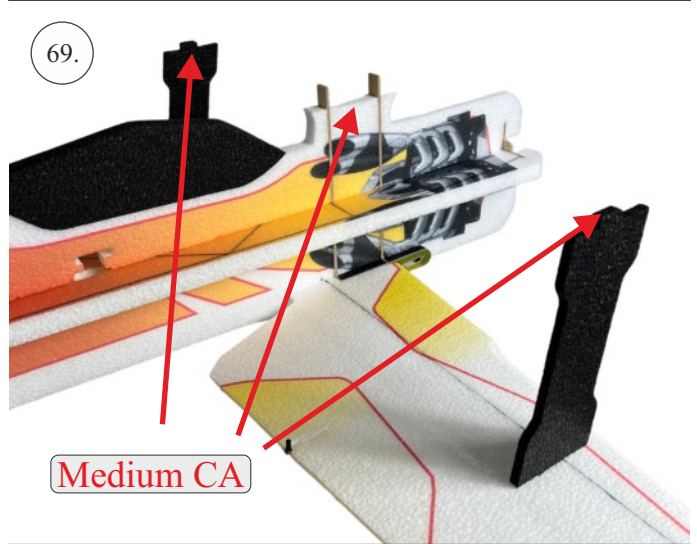
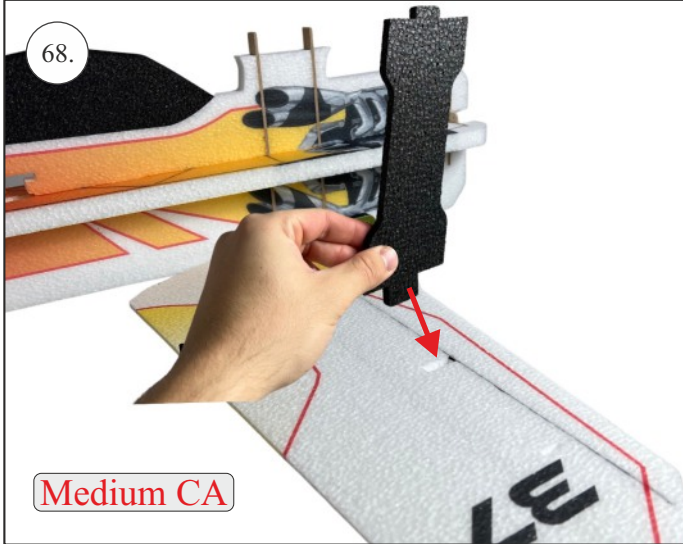
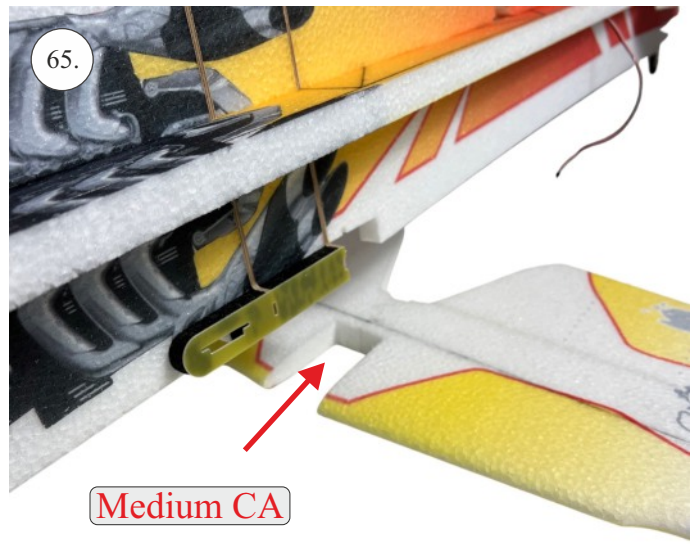

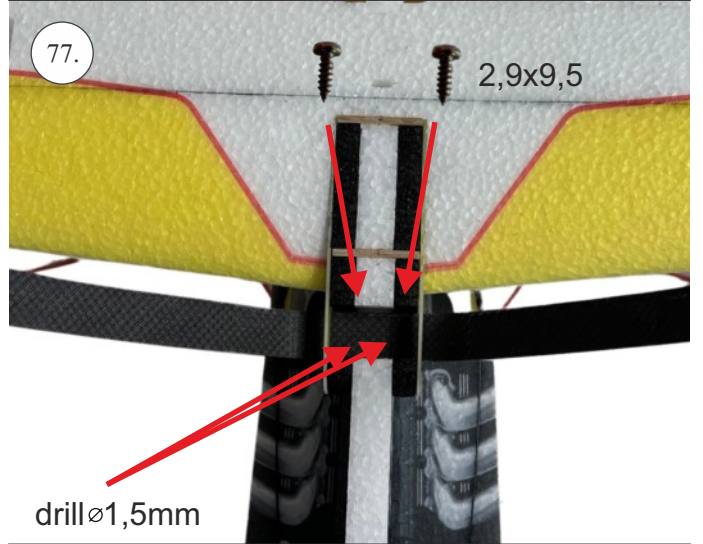
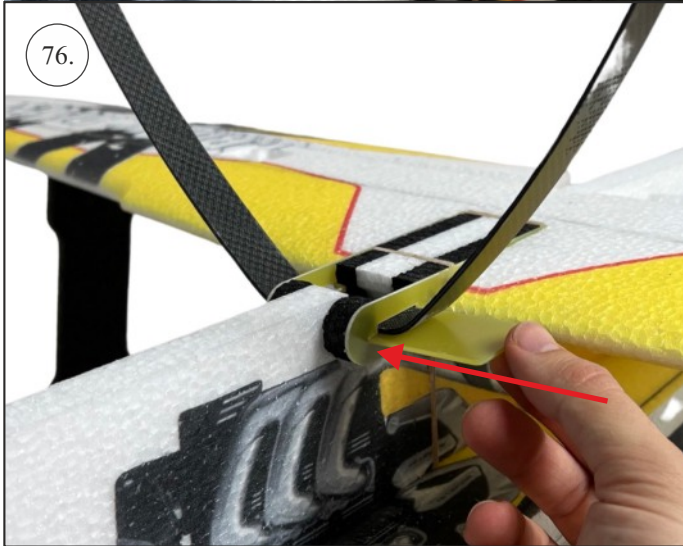
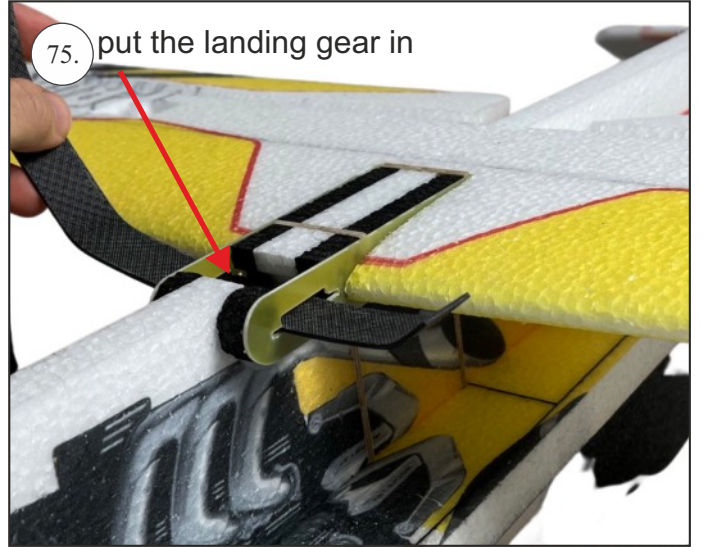
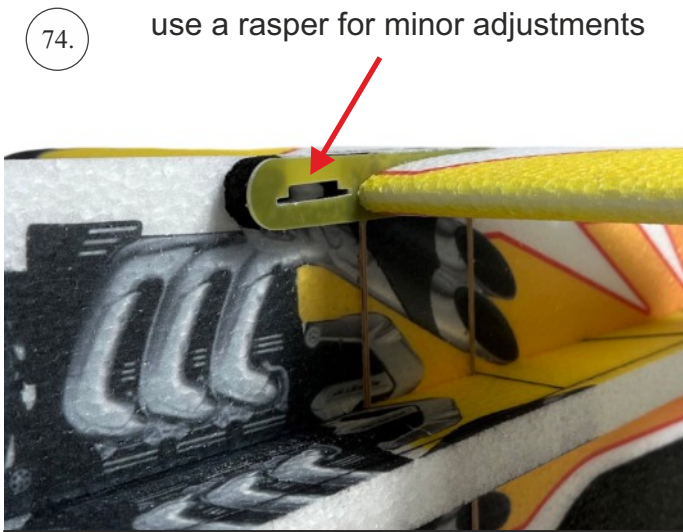
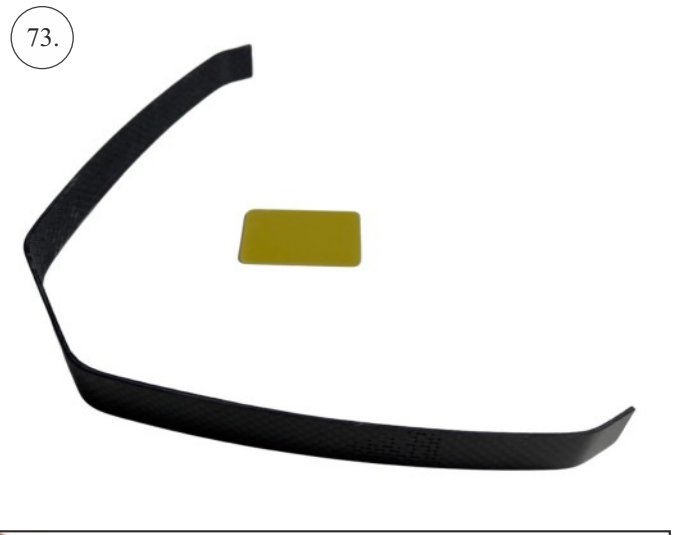
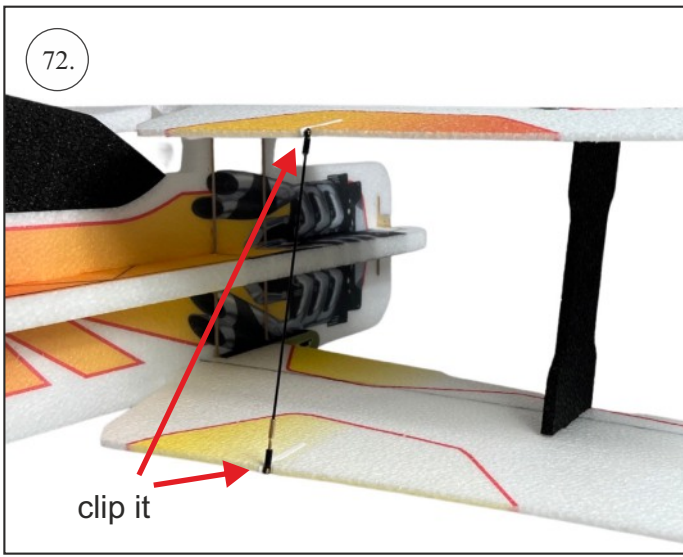

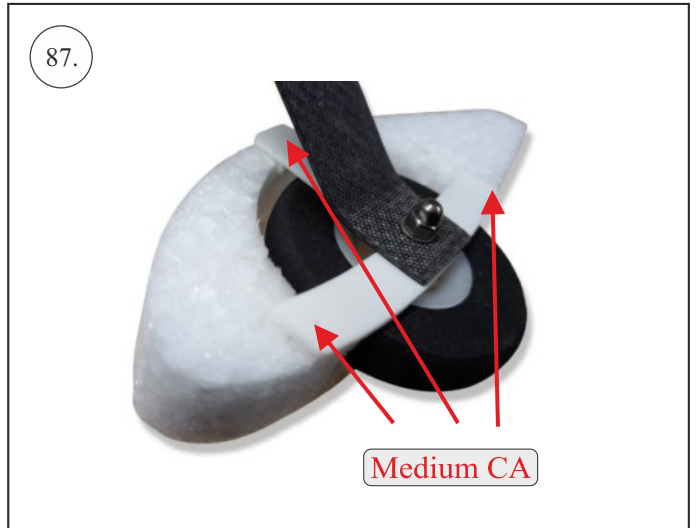
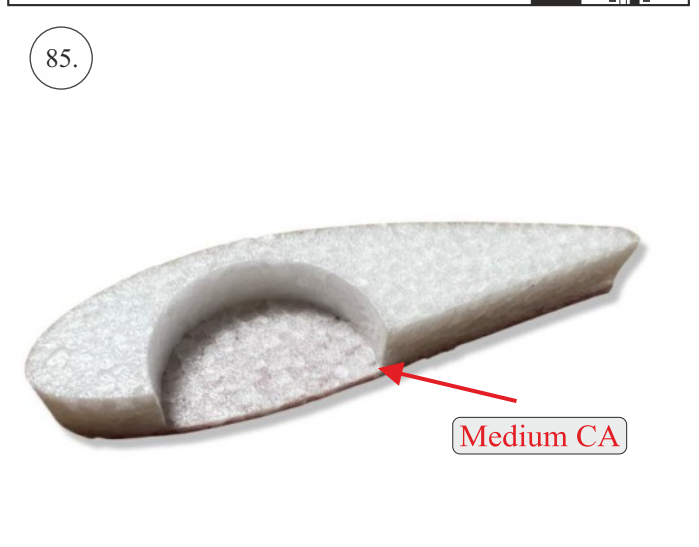
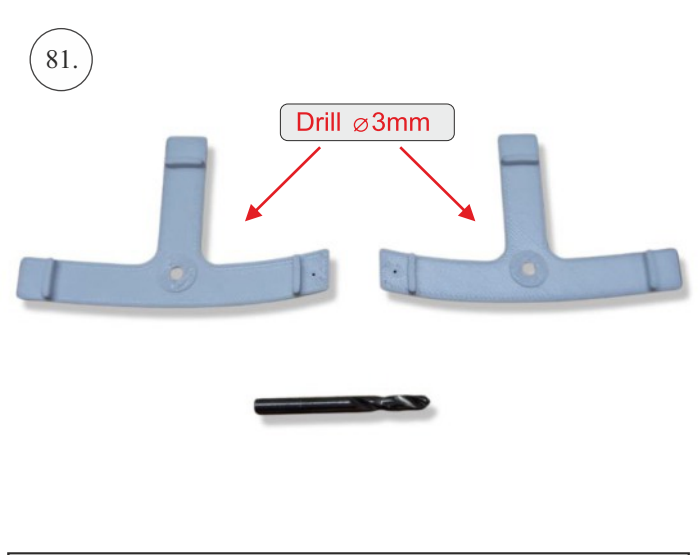
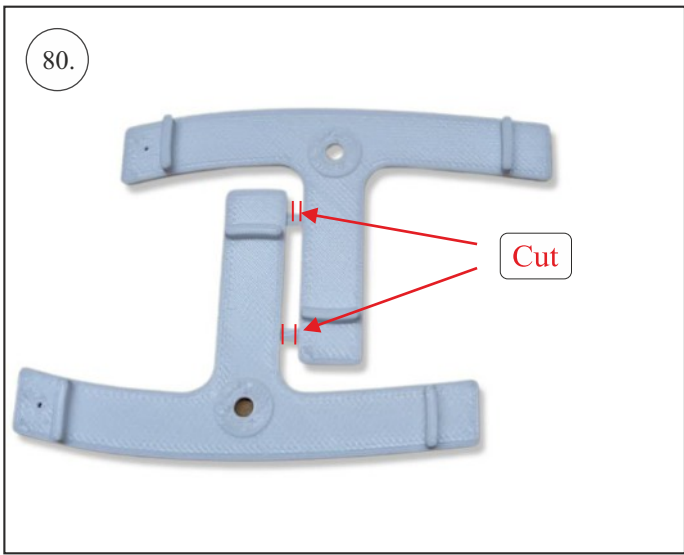

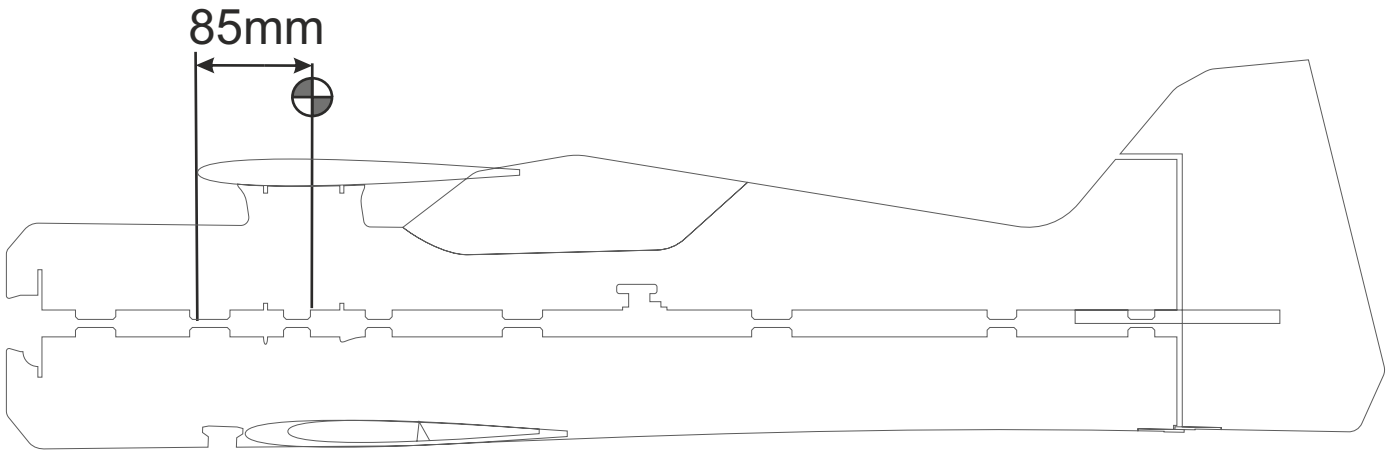

We wish you many happy flying hours with the Crack Pitts XL.

Your RC Factory team